

ARES BT SLIDING GATE MOTOR

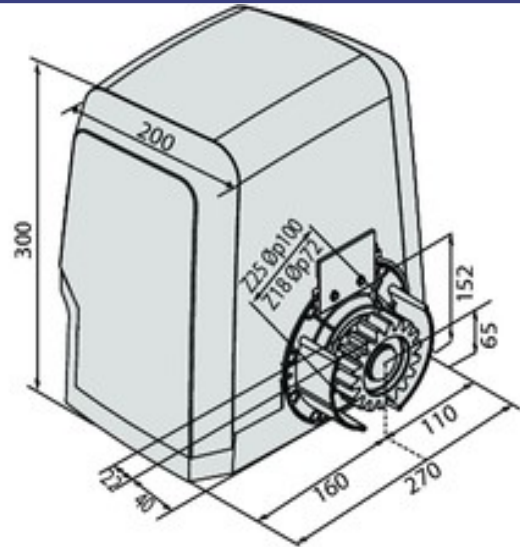

FEATURES

- 24v gate operator
- Magnetic limit switch and control board with U-link protocol embedded
- Simple and intuitive wiring
- Obstacle recognition
- Suitable for commercial & light industrial use

ACCESSORIES



Mobile Phone Gate Access



Keypad Access



Emergency Battery Backup

SPECIFICATIONS

CONTROL BOARD
MAX LEAF
GATE SPEED
POWER SUPPLY
MOTOR VOLTAGE
POWER INPUT
LIMIT SWITCH
PINION MODULE
SLOWDOWN
LOCKING
RELEASE

FREQUENCY OF USE
ENVIRONMENTAL CONDITIONS
PROTECTION RATING
ACTUATOR WEIGHT
IMPACT REACTION

ARES BT

MERAK
1000kg
12-14m/min
230v
24v
400w
Magnetic
4
Yes
Mechanical
Lever-operated with personal key
Intensive
-20 to +55°C
IP44
9kg
d-track

ARES FAST

MERAK
600kg
25m/min
230v
24v
400w
Mechanical
4
Yes
Mechanical
Lever-operated with personal key
Intensive
-20 to +55°C
IP44
9kg
d-track

Gate Opening Systems Pty Ltd

Factory 2 / 11 Leader Street

Campbellfield VIC 3061

Ph: 03 9305 3034

Website: www.gateopeningsystems.com.au

Email: gates@gateopeningsystems.com.au

- > Cantilever
- > Slide
- > Swing
- > Boom