



Test on impact force*

HT24 Electrohydraulic

LOW VOLTAGE (24V dc) HYDRAULIC SWING GATE OPERATOR. MAX LEAF LENGTH 6 M.



24V DC HYDRAULIC TECHNOLOGY



New distributor for best performance and max versatility



New metal release system PLUS accessible through lock for max security

- The electrohydraulic HALF TANK is a low voltage (24Vdc) hydraulic operator for swing gates satisfying the requirements of very exigent customers regarding quality and long time lasting.
- Hydraulic silence and reliability.
- SEA TOTAL QUALITY: All main parts are manufactured and tested in-house.
- The functioning of the operator through oil and the inner lubrication of all mechanical components grant a long time lasting.
- High Anti-crashing security through control unit with detecting amperometric function.
- Power and slow down adjustable on control unit USER.
- Versions with lock in both directions (AC) only in opening (SA) and without lock (SB).
- Application of emergency batteries for functioning in case of black -out possible.
- On request mechanical and electronic limit switches in opening and closing (optional)

CODE	NAME	PRICE	MAX LEAF WEIGHT	MAX LEAF LENGTH	MAX OPENING DEGREE	CYCLES/ HOUR	QX	QX
10403000	HALF TANK 270 ELECTROHYDRAULIC AC	€ 660,00	700 kg	1,8 mt	120°	70	16	32
10423000	HALF TANK 270 ELECTROHYDRAULIC SB	€ 655,00	700 kg	5,0 mt	120°	70	16	32
10503000	HALF TANK 390 ELECTROHYDRAULIC AC	€ 760,00	700 kg	2,2 mt	120°	70	16	32
10523000	HALF TANK 390 ELECTROHYDRAULIC SB	€ 755,00	700 kg	6,0 mt	120°	70	16	32

* Complete with mechanical and electronical stops and metallic release

STANDARD INSTALLATION FOR TWO SWING LEAVES

Code	Name	Quantity
10403000	HALF TANK ELETTRIDRAULICO AC	2
23024020	USER 24V	1
23110451	SMART DUAL Transmitter 2 ch. 433 Mhz	1
23120420	RF 433 Mhz radio frequency module	1
23104105	FLASH warning lamp 24V	1
23101075	Kit Antenna 433 MHz	1
23103050	KEY PLUS aluminium key switch	1
23102075	SUNSET BUS synchronized photocell	2
12710205	PILAR aluminium column for SUNSET	2

NOTE For leaf longer than 1,8 m it is suggested to use the versions SB with electric lock

OTHER ACCESSORIES

Codice	Nome
65000045	OILH Green oil for hydraulic motors (5lt)
12715070	BRA KIT fixation without welding LIBRA/ALPHA
23106305	BAT7 KIT Battery kit with box (7 AH)
23105276	JOLLY programmer for USER
23105276	KIT SUNNY (20 W solar panel +charger+batteries)
23101105	Control board for solar panel and USER 2 24V charger

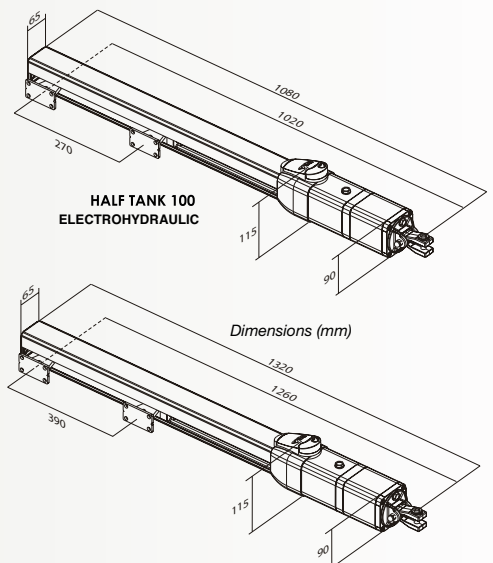

ACCESSORIES

Accessories for swing gates
General accessories

Page 38
Pag 99-102

